

Adaptive Array Antenna Using On-Off and CMA Algorithms for Microwave RFID Readers

Tanawut TANTISOPHARAK[†], Akkarat BOONPOONGA^{††}, Nonmembers,
Chuwong PHONGCHAROENPANICH[†], Member, Phaophak SIRISUK^{††}, Nonmember,
and Monai KRAIRIKSH^{†a)}, Member

SUMMARY This paper proposes an adaptive antenna using a combination of on-off and CMA algorithms. With the proposed technique, the on-off algorithm is first employed to search for a desired signal direction in which maximum received power is achieved. Then, interference is suppressed by performing CMA. Simulations are conducted according to the potential application of the proposed adaptive antenna. The simulation results show the SINR improvement implying that the proposed adaptive antenna can be applied to microwave RFID systems in order to resolve reader collision. Furthermore, the proposed adaptive antenna is implemented and then experimented. The experimental results verify that the proposed adaptive antenna can reduce interference resulting in the collision problem.

key words: adaptive antenna, on-off algorithm, CMA algorithm, microwave RFID readers

1. Introduction

Durian (*Durio zibethinus* Murry) is an important exporting fruit of Thailand that earns over a hundred million US\$ a year. An efficient supply chain management (SCM) system is required to deliver Durian to the end customer at the proper time. One of the effective methods improving the supply chain is a radio frequency identification (RFID) technology that can identify tagged objects via near/far-field wireless communications. A basic RFID system consists of two important components: transponder (tag) and interrogator (reader). Based on RFID technology, the underlying principle is to receive information from tags by using readers via radio frequency (RF) links. This provides its main advantage of trace and track for exporting Durian.

Besides SCM systems, the quality control and inspection for Durian are necessary to meet customers' satisfaction. Currently, the problem of mixing of mature and immature fruits disappoints the customers that downgrades the selling prize. Therefore, there is a need to standardize the quality to meet the requirements of the international market. Many techniques have been developed to classify Durian such as X-ray imaging and ultrasonic monitoring but none of them are applied in practical situation due to high cost. Recently, we presented a microwave technique using coupled patch antennas to monitor variation of dielectric proper-

ties correlated to chemical properties of Durian pulp that exhibits the possibility to classify Durian by using microwave [1], [2]. Although this technique can classify Durian reasonably, it is not suitable for supply chain management systems of export industries.

As aforementioned, RFID can be applied to provide the effective SCM. Furthermore, an RFID tag is also used as a low-cost sensor by mapping a change in some interesting physical parameters to a controlled change in electrical characteristics of the tag antenna [3], [4]. The design of RFID tags presented in [5], [6] will be used for sensing maturity stage of fruits by precisely matching the impedance of the tag with Durian fruit to the impedance of the chip. Then, the different received powers corresponding to Durian maturity stage is measured.

When there are many readers and/or tags operating in the same interrogation range of the reader, signals from one reader may reach other tags and/or readers and then cause interference or collision [7], for instance, in the Durian classification factories. There are a number of techniques utilized to resolve this collision [8]–[10]. The dynamic framed ALOHA was employed for an anti-collision algorithm to minimize the total time slots and the number of rounds required for identifying tags operating in the interrogation zone [8]. In [9], an anti-collision algorithm using effective slot allocation was proposed. The algorithm can reduce query iteration and transmission bit number. This leads to reduce the effect of collision. Typically, signals from one reader which reaches others cause interference called as the *reader collision*. The approach presented in [11] can adaptively adjust the RFID reader power to maintain the required signal-to-noise ratio (SNR).

Another technique which can be applied to reduce the effect due to collision is a smart antenna. The smart antenna was introduced to resolve the collision problem of RFID system [12]–[14] because there are some drawbacks of resolving the problem by using CDMA, FDMA, and TDMA mentioned in [12].

Recently, we presented an adaptive antenna using constant modulus algorithm (CMA). In our proposed system, a flat four beam antenna was employed as a receiving antenna to provide four radiation patterns in azimuth plane simply using one bit phase shifters [15]. A main beam with maximum received power was employed as an initial beam for CMA to improve convergence rate [16]. When square patches of one-wavelength width that provided switched-

Manuscript received November 30, 2010.

Manuscript revised February 3, 2011.

[†]The authors are with Faculty of Engineering, King Mongkut's Institute of Technology Ladkrabang, Bangkok 10520, Thailand.

^{††}The authors are with Faculty of Engineering, Mahanakorn University of Technology, Bangkok 10530, Thailand.

a) E-mail: kkmnai@kmitl.ac.th

DOI: 10.1587/transcom.E94.B.1153

beam patterns [17] were utilized in a phased array in [15], a variety of radiation patterns could be produced by selecting appropriate element patterns in each array element together with one-bit phase shifters. This antenna is called phased array of switched-beam elements (PASE) [18]. By selecting feed probes properly, the same radiation patterns as in [17] could be obtained with less sophisticated antenna fabrication [19]. The PASE using switched-probe elements was utilized for initializing CMA to improve convergence rate of the previous work in [16] and was revealed that the antenna could mitigate the effect of two interference signals [20].

Although the techniques in [16] and [20] do improve the convergence behavior, the hardware circuitry increases the size and the cost of the system, and the phase shifters also cause some signal loss. Digital beam synthesis [21] was proposed to digitally synthesize beams in different directions instead of using phase shifters. This technique utilizes complex weight vectors to multiply the received signal from the antenna in order to adjust the main beam to the desired direction. Due to its digital process, this system is compact and has low signal loss.

A combination of on-off and CMA algorithms was proposed in [22] to improve the performance of these two algorithms. This technique utilizes an on-off algorithm to track the desired signal direction and switches the main beam direction toward it. The signal with maximum received power was then exploited to initialize the CMA. However, the system has not been actually realized yet.

This work presents the design and experimental investigations of the combination algorithm of on-off and CMA algorithms that exhibits feasibility for microwave RFID reader application.

After an introduction, the system architecture of the combination algorithm of on-off and CMA algorithms is presented in Sect. 2. The potential application and simulation results are shown in Sect. 3. The system design, measurement setup and experimental results are described in Sect. 4 and a conclusion is drawn in Sect. 5.

2. System Architecture

Let consider the proposed adaptive antenna system, as shown in Fig. 1, consisting of N antenna elements for receiving microwave signals. The antennas are arranged as a uniform linear array along the x -axis with element spacing d . The complex signals received by i th element of the antenna are down-converted to lower frequencies in the operating range of analog-to-digital converters (ADCs). After digitization, the signals $\mathbf{x} = [x_0 \ x_1 \ \dots \ x_{N-1}]^T$ are fed into a processing unit consisting of an adaptive on-off processing unit, a digital power detector and a CMA adaptive processing unit. In the on-off processing [23], the outputs \tilde{x}_i obtained from the product of complex signals and weights of the on-off algorithm as defined by

$$\tilde{x}_i = u_i x_i \quad (1)$$

are combined together in order to be used to detect sig-

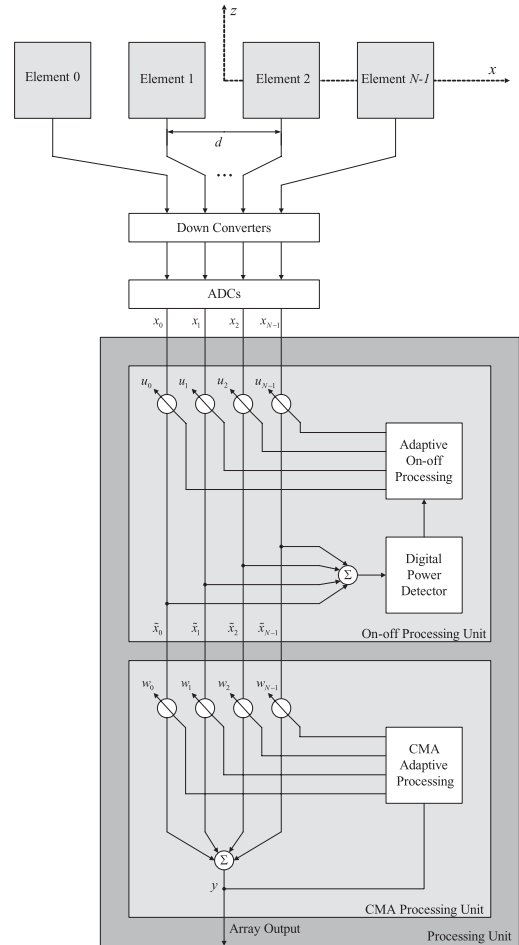

Fig. 1 Architecture of the proposed adaptive antenna.

nal power. Using matrix-vector notation, the weight can be rewritten as

$$\tilde{\mathbf{x}} = \mathbf{u}\mathbf{x}, \quad (2)$$

where $\tilde{\mathbf{x}} = [\tilde{x}_0 \ \tilde{x}_1 \ \dots \ \tilde{x}_{N-1}]^T$ and $\mathbf{u} = \text{diag}[u_0 \ u_1 \ \dots \ u_{N-1}]$ are input signal vector for CMA and chosen weight vector for on-off algorithm, respectively. The weights are automatically varied such that the maximum signal power is achieved. The weights are defined according to [21] as

$$u_i = e^{j\alpha_i}, \quad (3)$$

where α_i is the progressive phase between each element. The weights employed to produce the input for CMA can be obtained from update phase equation defined by [23].

$$\alpha_i(n+1) = \alpha_i(n) + \mu_\alpha \text{sign}(\nabla P), \quad (4)$$

where n is index time of processing of the on-off algorithm, μ_α is the adaptive gain of the updating phase and ∇P is the gradient of the output power.

Given the maximum power, the weights are chosen to provide the main beam direction close to the desired signal direction. The array output of the proposed adaptive antenna is constructed by multiplication of adjustable weight vector

$\mathbf{w}(k) = [w_0(k) \ w_1(k) \ \dots \ w_{N-1}(k)]^T$ and output of on-off algorithm $\tilde{\mathbf{x}}(k) = [\tilde{x}_0(k) \ \tilde{x}_1(k) \ \dots \ \tilde{x}_{N-1}(k)]^T$ as

$$y(k) = \mathbf{w}(k)^H \tilde{\mathbf{x}}(k). \quad (5)$$

Or

$$y(k) = \mathbf{w}(k)^H \mathbf{u}\mathbf{x}(k), \quad (6)$$

where k is index time of CMA processing. Following the cost function presented in [24], the stochastic gradient steepest descent method is used for adaptation. This results in the weight vector which can be updated by the following equation

$$\mathbf{w}(k+1) = \mathbf{w}(k) - 4\mu \tilde{\mathbf{x}}(k) y^*(k) (|y(k)|^2 - \sigma^2). \quad (7)$$

By substituting (1) and (5) into (6), the update weight equation can be rewritten as

$$\mathbf{w}(k+1) = \mathbf{w}(k) - 4\mu |\mathbf{u}|^2 |\mathbf{x}(k)|^2 \mathbf{w}^T(k) \cdot (|\mathbf{w}^H(k) \mathbf{u}\mathbf{x}(k)|^2 - \sigma^2) \quad (8)$$

where μ is the step-size of the CMA and σ is the amplitude of the array output in absence of the interference.

3. Potential Application and Simulations

3.1 Potential Application

Figure 2 illustrates the potential scenario of the Durian classification system comprising N readers aligned parallel to each other. An RFID tag sensor is located beneath a conveyor carrying Durian fruits. To achieve the maximum Durian-classification number with the limited operation area, the reader should be installed as close as possible.

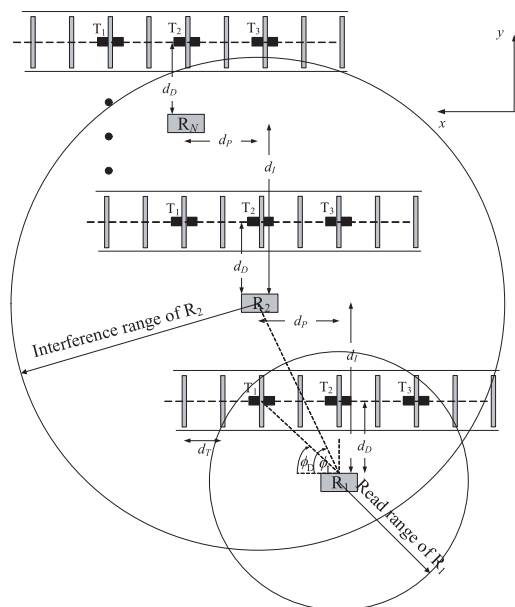

Fig. 2 Potential scenario of Durian classification system.

In a dense RFID network, there are multiple of readers operating in the same interrogation zone as seen in the figure. The transmission collision may occur. It is difficult to allocate the different frequency channel to resolve the interference due to the limited spectrum bands [12]. In our scenario of Durian classification, even though we align the readers to shift from each other with spacing d_p , this is not adequate to resolve the problem. In this paper, we propose the adaptive antenna system which can resolve the interference problem occurred in the RFID-based Durian classification systems.

The proposed adaptive antenna is installed along with a reader to eliminate interference due to the neighboring reader. Reconsidering Fig. 2, the signal from the antenna of the reader 2 (R_2) interferes that of reader 1 (R_1). Let angles of signal from R_2 and tag incident to R_1 be ϕ_I and ϕ_D , respectively. The distance between neighboring readers is d_I . To increase the measurement accuracy for Durian classification, three tags are aligned along x-axis with spacing d_T . This is for an inspector to assure that the measurement accuracy is high. The distance of the reader perpendicular to tag position is d_p . By using our proposed adaptive antenna, the on-off algorithm is first used to switch its main beam toward a tag direction. To obtain information from the desired tag without interference due to neighboring reader, an adaptive antenna is required. We therefore introduce CMA to eliminate interference. Similarly, the adaptation for other tags will be conducted. At the reader, different tags result in different received powers mapping to the electrical characteristic of Durian. The characteristic will be changed to be maturity stage of Durian.

3.2 Simulations

To evaluate the proposed adaptive antenna, simulations were conducted in accordance with the potential scenario mentioned above. Let us consider a two-element array with half-wavelength spacing. In simulations, the signal-to-noise ratio (SNR) was set to be 20 dB. According to Fig. 2, the simulations were divided into three different cases for three different tag positions. Here, we set the d_D and d_I being 0.5 m and 1.5 m, respectively. The interference direction ϕ_I was therefore set as 56° . When the reader needs information from tag T_1 , the desired signal was set as tag T_1 whose incident angle is $\phi_D = 45^\circ$ (case (a)). This angle value is obtained from setting tag spacing d_T being 0.5 m. The incident angle of desired signal was moved to $\phi_D = 90^\circ$ and $\phi_D = 135^\circ$ in case (b) and (c) according to positions of tag T_2 and T_3 , respectively.

In case (a), an on-off algorithm was first employed to choose the direction of the main beam with the maximum received power. Here, the main beam of the antenna was switched to $\phi_D = 45^\circ$ then CMA was performed. Figure 3(a) shows radiation patterns obtained from the adaptive antenna using on-off algorithm with and without CMA at 14,000 iterations. The nullity of the radiation pattern obtained from the proposed adaptive antenna appears at the direction of interference. With only on-off algorithm, the main beam of

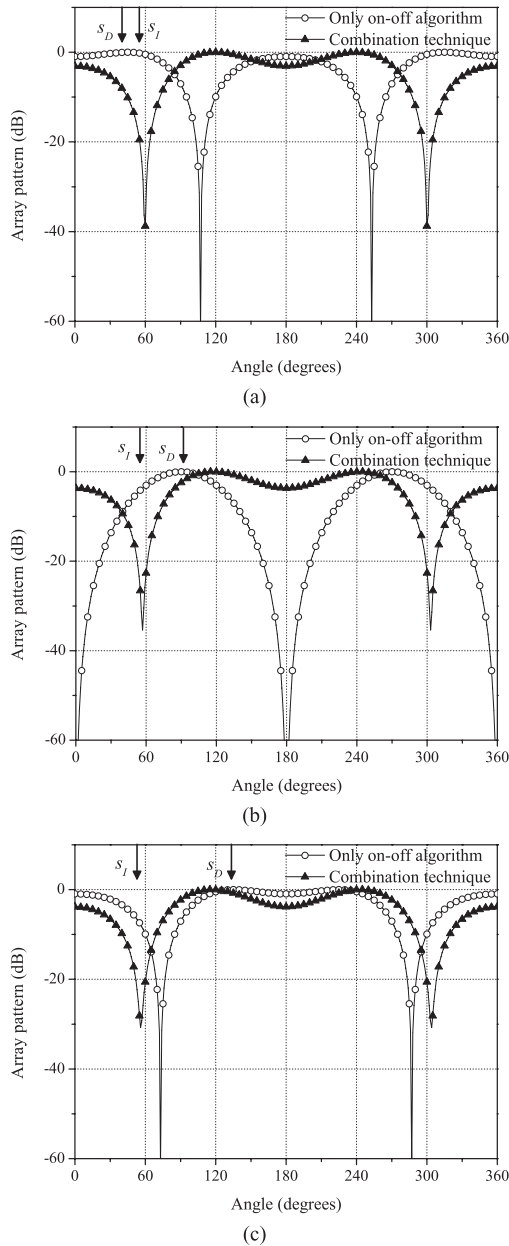

Fig. 3 Radiation patterns (a) $\phi_D = 45^\circ$, $\phi_I = 56^\circ$ (b) $\phi_D = 90^\circ$, $\phi_I = 56^\circ$ (c) $\phi_D = 135^\circ$, $\phi_I = 56^\circ$.

the antenna directs to the desired signal but the direction of nullity and interference is not coincident. This implies that SINR improvement by using a combination of CMA and on-off algorithm is better than that by using only on-off algorithm.

Similar to simulation in case (a), the main beam directions of the antenna are switched to be 90° and 135° as initial beams for case (b) and (c), respectively. Figures 3(b) and (c) show the radiation patterns of case (b) and (c) at 4,000 iterations, respectively. In the figures, the main beams of the antenna obtained from only on-off algorithm direct to the directions of the desired signals. Their nullities do not appear in the direction of interference. In contrast, by using

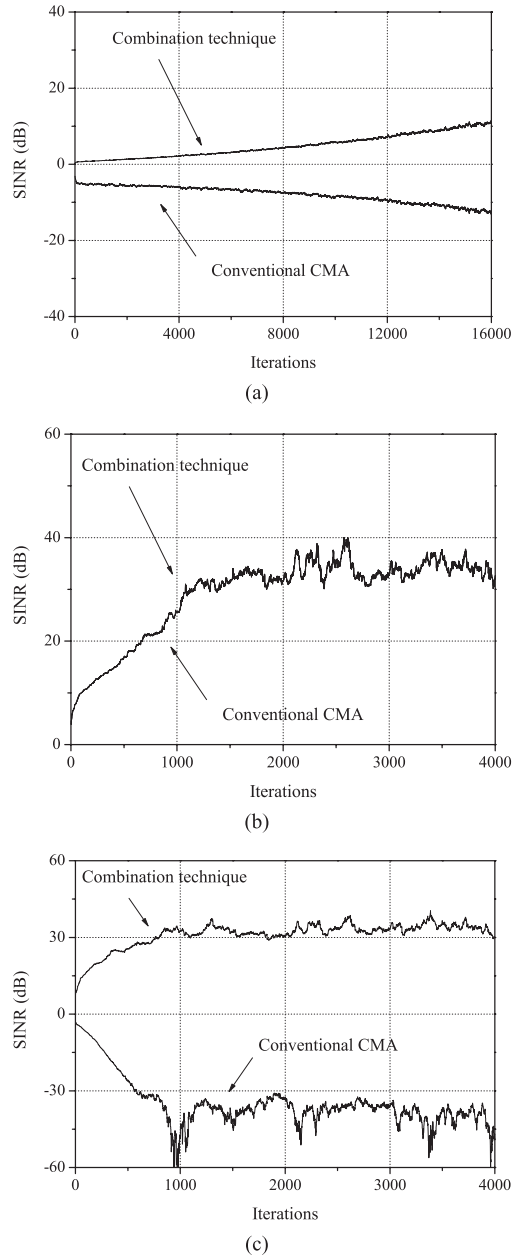

Fig. 4 SINR trajectories (a) $\phi_D = 45^\circ$, $\phi_I = 56^\circ$ (b) $\phi_D = 90^\circ$, $\phi_I = 56^\circ$ (c) $\phi_D = 135^\circ$, $\phi_I = 56^\circ$.

a combination of CMA and on-off algorithms, although desired signals are not received by a peak of radiation pattern, they are in the main beam and the nullities of the antenna appear at the interference direction.

So far, convergence properties of CMA with and without on-off algorithm must be determined to confirm that the proposed technique has superior convergence. SINR trajectories obtained from CMA with and without on-off algorithm in different simulation cases are shown in Figs. 4(a)–(c). In case (a) and (c), the antennas using CMA without on-off algorithm have misconvergence. In case (a), since the initial main beam direction of the adaptive antenna using a conventional CMA is 90° , the incident angle of in-

interference ($\phi_I = 56^\circ$) is closer to the main beam direction (90°) than that of the desired signal ($\phi_D = 45^\circ$). This results in misconvergence in conventional CMA. Straightforwardly, the conventional CMA in case (c) misconverges because the desired signal direction being $\phi_D = 135^\circ$ is farther to the initial main beam (90°) for conventional CMA than interference direction being $\phi_I = 56^\circ$. Furthermore, in case (a), the convergence property of CMA with and without on-off algorithm seems to be slow because the angle space between desired and interference signals is small [16]. In case (b), the SINR trajectories obtained from the antenna using CMA with and without on-off algorithm are almost identical because an initial beam obtained from on-off algorithm is identical to that one without on-off algorithm. According to case (a)–(c), it should be noted that by using CMA with on-off algorithm, when the initial main beam of the antenna is automatically switched toward to the desired signal, the antenna can converge to capture desired signal (not interfere) at all. Although all simulations show that the proposed adaptive antenna has superior capturing behavior, it may misconverge if power of interference is stronger than that of the desired signal.

4. Design and Experimental Results

4.1 Experimentation Setup

To demonstrate the proposed system, two patch antennas were designed to operate at 2.4 GHz. The designed patch antennas were fabricated on an FR-4 substrate whose ϵ_r was 4.36 and h was 1.441 mm. The dimensions are listed in Fig. 5(a).

The centers of the patches were separated by 6.125 cm (0.5 λ). The antennas were well matched to 50 Ω with return losses of -18 and -20 dB at the designed frequency. Directional patterns were almost identical with a gain of 7.7 dBi. Half power beamwidths in E- and H-planes were 48° and 62° , respectively. The down converters in Fig. 5(b) utilized MAX2102 operating at 2.4 GHz which is in its expanded-frequency range. The output signals were amplified by a hi-speed amplifier OPA842. Hence, the conversion gain was 45 dB. Then they were converted to digital signals by using ADS831 analog-to-digital converters. I and Q outputs from each channel were calibrated to obtain equal amplitude and phase. Then, they were input into an adaptive algorithm implemented on a Xilinx Virtex-E XCV400E FPGA. Total gates of 569,952 were utilized.

Agilent N5182A vector signal generator was used for transmitting the desired QPSK signal at 2.4 GHz via a microstrip antenna whereas an Agilent 8648C signal generator was used for transmitting the interference signal. The configuration of the measurement setup is shown in Fig. 5(c). The receiving antennas were mounted on a movable carriage with a length of 60 cm. The carriage was moved at 1.5 cm per step and the received signals were captured 40 times to a personnel computer connected to the output of the FPGA via JTAG USB interface. The averaged signal strength at

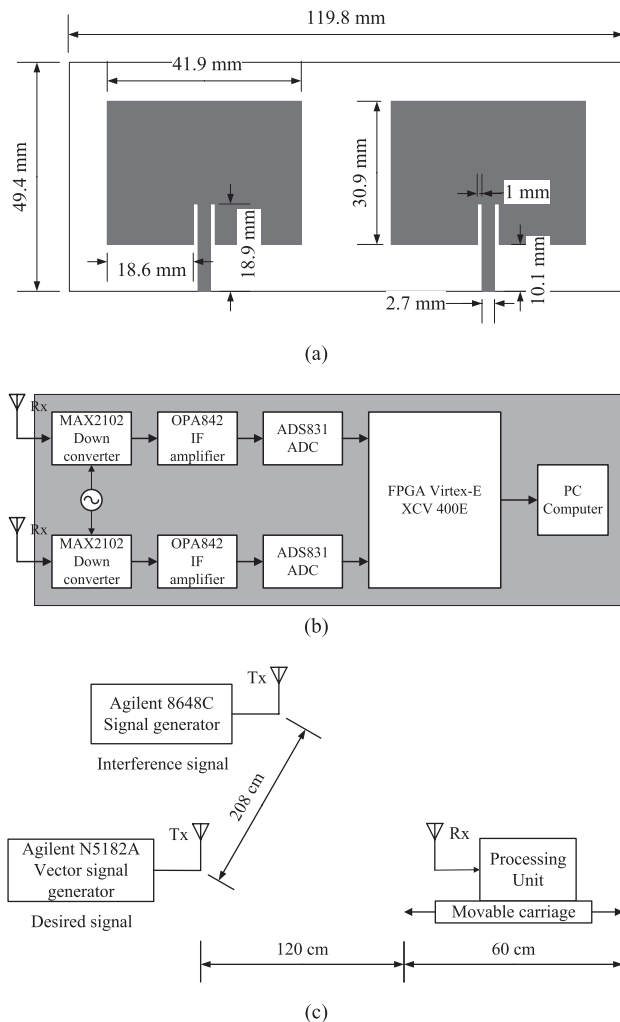

Fig. 5 Diagram of the system (a) antenna array (b) block diagram of the designed system (c) configuration of the measurement setup.

each position was plotted. Those for the CMA and the combination of on-off and CMA algorithms are shown in Fig. 6. The improvement in signal strength is clearly observed.

4.2 Experimental Results

From the field strength observed in Fig. 6, the on-off algorithm-only received signal was at a higher level than that of the single antenna. The received signal level of the CMA-only and the combination techniques were slightly different but higher than those from the on-off only algorithm and the single antenna. The CDF curves corresponding to the received signal level in Fig. 6 are shown in Fig. 7.

The CMA adaptive antenna had an adaptive gain of 6 dB. The adaptive antenna using on-off and CMA algorithms provided an improvement in adaptive gain to 7 dB. It should be noted that with this improved adaptive gain, read range can be increased by 2.24 times from that of the single antenna counterpart [25].

To confirm that the proposed adaptive antenna can

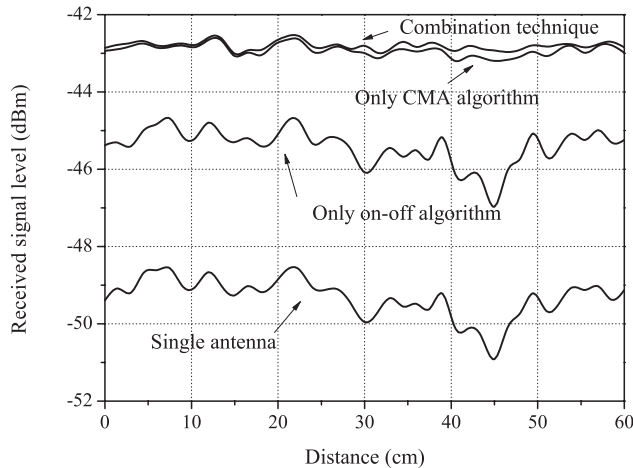

Fig. 6 Field strength VS position.

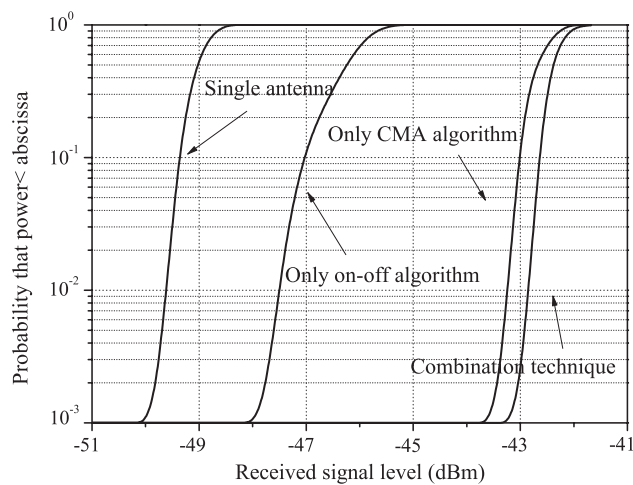

Fig. 7 CDF curve of received signal level.

operate in practical situation, the error vector magnitude (EVM) calculated from the measured signal constellation should be determined. The EVM can be defined as [26]

$$EVM_{RMS} = \left[\frac{1}{T} \sum_{r=1}^T \left(|I_r - I_{0,r}|^2 + |Q_r - Q_{0,r}|^2 \right) \right]^{\frac{1}{2}} \quad (9)$$

where

T is the number of the symbols for the measurement;

I_r, Q_r denotes the in-phase and quadrature components of the measured symbol point, respectively;

$I_{0,r}, Q_{0,r}$ denotes the in-phase and quadrature components of the ideal symbol point, respectively;

P_0 is the average power of the constellation.

The measurement for the signal constellation was setup in accordance with case (a) of simulation. The desired and interference signal angles are 45° and 56° , respectively. Table 1 lists the EVM calculated from the measured signal constellation of the antenna with CMA only, on-off only, and a combination between CMA and on-off algorithms af-

Table 1 EVM and total response of the systems.

Systems	EVM	Total response	Weight vectors
Only on-off algorithm	1.0325	$[0.551e^{j0.345}$ $0.821e^{j0.869}]$	$[1 + j0$ $-0.606 + j0.796]$
Only CMA algorithm	0.3757	$[0.355e^{j0.385}$ $0.749e^{j0.316}]$	$[0.079 - j0.009$ $0.735 + j0.059]$
CMA and on-off algorithm	0.2379	$[0.894e^{-j1.95}$ $0.414e^{-j2.02}]$	$[-0.076 - j0.023$ $0.67 - j0.309]$

ter converge at 14,000 iterations. The EVM obtained from the antenna with on-off algorithm is highest of 1.0325. It implies that output signals of the on-off algorithm contain both of desired and interference signals. Clearly, interference cannot be completely eliminated by using only on-off algorithm. Note that EVM obtained from measured outputs of a combination of CMA and on-off algorithms of 0.2379 is obviously lower than that from the only CMA algorithm of 0.3757. This shows the superior constellation and confirms that the combination of CMA and on-off algorithm can mitigate the effect of interference.

Using Wiener's equation [27], the total response vector is

$$\mathbf{q} = \mathbf{w}^H \mathbf{H} \quad (10)$$

where H denotes vector conjugate transpose, \mathbf{w} and \mathbf{H} are complex weight and array response matrix, respectively.

In our context, $\mathbf{q} = [Ae^{j\theta} \ 0]$, where A and θ are scaling factor and overall phase shift, corresponds to the situation that the antenna has captured the desired signal and $\mathbf{q} = [0 \ Ae^{j\theta}]$ if the antenna has captured the interference signal.

The total responses of the systems in the experiments are also shown in Table 1. Note that the total responses of the adaptive antenna using on-off only algorithm were not close to $[Ae^{j\theta} \ 0]$ because its weight vector, obtained from the progressive phase of the antenna for beam switching, did not equalize the signal like in other cases. By using only CMA algorithm, the scaling factor A corresponding to direction of the desired signal is higher than that corresponding to direction of interference. This implies that the CMA captures interference rather than the desired signal. On the other hand, when applying CMA with on-off algorithms to an adaptive antenna, the scaling factors corresponding to direction of desired and interference signal are 0.894 and 0.414, respectively. It is clear that the antenna can capture the desired signal and reduce interference.

5. Conclusion

A combination of on-off and CMA algorithms has been proposed and its performance was investigated via simulations and experimentation. In the proposed technique, the on-off algorithm was first employed to direct the main beam direction towards to the desired signal direction. The output of the algorithm was then fed to CMA processing. In this

paper, simulations show that the proposed adaptive antenna can capture the desired signal and reduce interference although the direction of the signals was changed. Comparing to the antenna without an adaptive algorithm, the proposed adaptive antenna achieves SINR improvement. This implies that the reader collision can be resolved. Finally, the proposed adaptive antenna was implemented and then experimented. The experimental results verify that the proposed adaptive antenna can reduce interference successfully. It is noticed that the proposed adaptive antenna can be referred as an effective low-cost solution for microwave RFID readers since all additional circuitries including on-off and CMA processing can be implemented on a single digital processing unit (FPGA).

Acknowledgments

The authors appreciate the editorial members for comments that significantly improve the manuscript. This work was supported by the Thailand Research Fund (TRF) through the Royal Golden Jubilee Ph.D. Program (Grant No. PHD/0344/2550 and the senior research scholar project (Grant No. RTA5180002).

References

- [1] S. Suttapa, J. Varith, M. Krairiksh, C. Noochuay, and J. Phimpimol, "Microwave sensor response in relation to Durian maturity," Proc. CIGR Section VI International Symposium on Food Processing and Monitoring Technology in Bioprocesses and Food Quality Management, Potsdam, Germany, Sept. 2009.
- [2] M. Krairiksh, J. Varith, A. Kanjanavapastit, C. Phongcharoenpanich, A. Thanachayanont, P. Sirisuk, and M. Chongcheawchamnan, "Microwave sensor for Durian inspection," Proc. 2009 IEEE International Conference on Antennas, Propagation and Systems (INAS 2009), pp.221-1–221-4, Johor, Dec. 2009.
- [3] H. Zangl, A. Fuchs, T. Brettertklieber, M.J. Moser, and G. Holler, "Wireless communication and power supply strategy for sensor applications within closed metal walls," IEEE Trans. Instrum. Meas., vol.59, no.6, pp.1686–1692, June 2010.
- [4] R. Bhattacharyya, C. Floerkemeier, and S. Sarma, "Low-cost, ubiquitous RFID-tag-antenna-based sensing," Proc. IEEE, vol.98, no.9, pp.1593–1600, Sept. 2010.
- [5] P. Wongsiritorn, C. Phongcharoenpanich, D. Torrungrueng, and M. Krairiksh, "UHF-RFID tag antenna design using dipole with parasitic lines," Proc. 2009 Electrical Engineering/Electronics, Computer, Telecommunications, and Information Technology International Conference (ECTI-CON2009), vol.2, pp.794–797, Pattaya, May 2009.
- [6] P. Wongsiritorn, C. Phongcharoenpanich, D. Torrungrueng, and M. Krairiksh, "UHF RFID tag antenna design using meander-line with semi-circular structure," Proc. Thailand-Japan Microwave 2009 (TJMW2009), pp.119–122, Bangkok, 2009.
- [7] D.W. Engels and S.E. Sarma, "The reader collision problem," Proc. 2002 IEEE International Conference on Systems, Man and Cybernetics, vol.3, Oct. 2002.
- [8] C.W. Lee, H. Cho, and S.W. Kim, "An adaptive RFID anti-collision algorithm based on dynamic framed ALOHA," IEICE Trans. Commun., vol.E91-B, no.2, pp.641–645, Feb. 2008.
- [9] S. Kim, Y. Kim, and K. Ahn, "An interference algorithm with efficient slot allocation for RFID tag identification," IEICE Trans. Commun., vol.E93-B, no.1, pp.170–173, Jan. 2010.
- [10] Y. Tanaka and I. Sasase, "Interference avoidance algorithms for passive RFID systems using contention-based transmit abortion," IEICE Trans. Commun., vol.E90-B, no.11, pp.3170–3180, Nov. 2007.
- [11] K. Cha, S. Jagannathan, and D. Pommerenke, "Adaptive power control protocol with hardware implementation for wireless sensor and RFID reader networks," IEEE Syst. J., vol.1, no.2, pp.145–159, Dec. 2007.
- [12] J. Yu, K.H. Liu, X. Huang, and G. Yan, "An anti-collision algorithm based on smart antenna in RFID system," Proc. 2008 International Conference on Microwave and Millimeter Wave Technology (ICMMT2008), vol.3, pp.1149–1152, April 2008.
- [13] M.S. Sayeed and Y.S. Kim, "A simple LMS algorithm based smart antenna to solve the reader collision problems in RFID system," Proc. 2009 International Conference on Information and Multimedia Technology, pp.426–430, 2009.
- [14] P. Salonen and L. Sydanheimo, "A 2.45 GHz digital beam-forming antenna for RFID reader," Proc. IEEE 55th Vehicular Technology Conference (VTC2002), vol.4, pp.1766–1770, 2002.
- [15] M. Krairiksh, P. Ngamjanporn, and C. Kessuwan, "A flat four-beam compact phased array antenna," IEEE Microw. Wireless Compon. Lett., vol.12, no.5, pp.184–186, May 2002.
- [16] A. Boonpoonga, P. Sirisuk, M. Chongcheawchamnan, S. Patisang, and M. Krairiksh, "Hardware-assisted initialization for CMA adaptive antenna," IET Microwave, Antenna and Propagation, vol.2, no.4, pp.303–311, 2008.
- [17] P. Ngamjanyaporn and M. Krairiksh, "Switched-beam single patch antenna," Electron. Lett., vol.38, no.1, pp.7–8, Jan. 2002.
- [18] P. Ngamjanyaporn, C. Phongcharoenpanich, P. Akkaraekthalin, and M. Krairiksh, "Signal-to-interference ratio improvement by using a phased array antenna of switched-beam elements," IEEE Trans. Antennas Propag., vol.53, no.5, pp.1819–1828, May 2005.
- [19] J. Tagapanij, C. Phongcharoenpanich, and M. Krairiksh, "A dual feed switched-beam patch antenna for a phased array of switched-beam elements," Proc. 2006 Asia-Pacific Microwave Conference, vol.3, pp.2102–2105, Yokohama, Dec. 2006.
- [20] M. Krairiksh, "A handset adaptive antenna using phased-array of switched-beam elements," J. Jpn. Soc. of Applied Electromagnetics and Mechanics, vol.17, no.3, pp.407–412, Sept. 2009.
- [21] T. Tantisoparak, A. Boonpoonga, P. Sirisuk, and M. Krairiksh, "Simple initialization scheme for CMA adaptive antenna by using digital beam synthesis," Proc. Int. Conf. Electrical Engineering/Electronics, Computer, Telecommunications and Information Technology (ECTI-CON 2008), vol.1, pp.I-289–I-292, Krabi, May 2008.
- [22] T. Tantisoparak, A. Boonpoonga, P. Sirisuk, and M. Krairiksh, "Combination between CMA and on-off algorithms for adaptive array antenna," Proc. 2009 International Symposium on Antennas and Propagation (ISAP 2009), Bangkok, Oct. 2009.
- [23] T.A. Denidni, D. Mcneil, and G.Y. Delisle, "A nonlinear algorithm for output power maximization of an indoor adaptive phased array," IEEE Trans. Electromagn. Compat., vol.37, no.2, pp.201–209, May 1995.
- [24] J.R. Treichler and B.G. Agee, "A new approach to multipath correction of constant modulus signals," IEEE Trans. Acoust. Speech Signal Process., vol.ASSP-31, no.2, pp.459–472, April 1983.
- [25] K. Finkenzeller, RFID Handbook, 2nd ed., Wiley, New York, 2003.
- [26] M.D. McKinley, K.A. Remley, M. Myslinski, J.S. Kenny, D. Schreurs, and B. Nauwelaers, "EVM calculation for broadband modulated signals," 64th ARFTG Conf. Dig., pp.45–52, Orlando, Dec. 2004.
- [27] D. Liu and L. Tong, "An analysis of constant modulus algorithm for array signal processing," Signal Process., vol.73, pp.81–104, 1999.



Tanawut Tantisoparak was born in Bangkok, Thailand. He received the B.Eng. and M.Eng. from King Mongkut's Institute of Technology Ladkrabang (KMITL), Bangkok, Thailand, in 2005 and 2009, respectively. He is currently working toward the D.Eng. at the same institute.



Akkarat Boonpoonga was born in Surin, Thailand, in 1980. He received the B.Eng. degree in Electrical Engineering from King Mongkut's Institute of Technology North Bangkok (KMITNB), Bangkok, Thailand in 2002 and M.Eng. degree in Telecommunications Engineering from King Mongkut's Institute of Technology Ladkrabang (KMITL), Bangkok, Thailand in 2004. He received the D.Eng. Degree in Electrical Engineering in the same institute in 2008. He is presently a lecturer at Department of Computer Engineering, Mahanakorn University of Technology. His research interest includes an adaptive antenna and FPGA design for wireless communication systems.

department of Computer Engineering, Mahanakorn University of Technology. His research interest includes an adaptive antenna and FPGA design for wireless communication systems.



Chuwong Phongcharoenpanich was born in Nakhon Prathom, Thailand. He received the B.Eng. (Hons), M.Eng., and D.Eng. degrees from the Faculty of Engineering, King Mongkut's Institute of Technology Ladkrabang (KMITL), Bangkok, Thailand, in 1996, 1998, and 2001, respectively. He is currently an Assistant Professor at the Department of Telecommunication Engineering, KMITL. His research interests are antennas for mobile and wireless communications, conformal antennas and array theory. Dr. Phongcharoenpanich is a Member IEEE and ECTI Association of Thailand.

theory. Dr. Phongcharoenpanich is a Member IEEE and ECTI Association of Thailand.



Phaophak Sirisuk received the B.Eng. degree (with honors) in Telecommunication Engineering from King Mongkut's Institute of Technology Ladkrabang, Bangkok, Thailand, in 1992, and M.Sc. and Ph.D. from Imperial College of Science Technology and Medicine, UK, in 1994 and 2000 respectively. He is currently an Assistant Professor at Department of Computer Engineering, Mahanakorn University of Technology, Bangkok, Thailand. His research interest includes signal processing, adaptive filtering, artificial intelligent control and integrated circuit design.

filtering, artificial intelligent control and integrated circuit design.



Monai Krairiksh was born in Bangkok. He received B.Eng., M.Eng. and D.Eng. from King Mongkut's Institute of Technology Ladkrabang (KMITL) in 1981, 1984 and 1994, respectively. He joined the KMITL and is presently a professor at the Department of Telecommunication Engineering. He has served as the director of the Research Center for Communications and Information Technology (ReCCIT) during 1997-2002. Dr. Krairiksh is currently a president of the Electrical Engineering/Electronics,

Computer, Telecommunications and Information Technology Association (ECTI). He is an editor of the ECTI Transactions on Electrical Eng., Electronics and Communications. He was awarded a Senior Research Scholar of the Thailand Research Fund (TRF) in 2005 and 2008. His main research interests are in antennas for mobile communications and microwave in agricultural applications.