

Innovations Leading Capsule Endoscopy into the New Frontier: Screening and Therapy at Home

Hidetoshi OHTA^{†a)}, *Member*

SUMMARY This paper proposed patient friendly capsule endoscopy (CE) for not only screening but also treatment. Two different types of CEs with an Internet utility were investigated. The first type used magnetic navigation in the stomach and colon for screening. Magnetic navigation enabled the capsule to explore the whole of the gastrointestinal tract with less risk of missing lesions and complete the screening within the battery life. The system's design was patiently friendly as it allowed the subjects to leave the hospital after the capsule had been navigated in the stomach. The second investigated two different therapeutic robotic endoscopes. Both prototypes were driven by DC motors and controlled remotely via the internet. In addition, they were equipped with therapeutic tools and each prototype's ability with the tools was assessed. The investigation showed it was possible to remotely control both prototypes and operate therapeutic tools via the Internet. The investigation identified areas for improvement, such as size, connection speed, security of data, and the holding the capsule's position during treatment. In conclusion, both methods have the potential to make capsule endoscopy a very patient friendly procedure that can be carried out anywhere.

key words: *capsule endoscopy, magnetic navigation, robotic endoscope, remote control, Internet*

1. Introduction

Capsule endoscopy (CE) was clinically introduced 14 years ago by Given Imaging and has been improved to extend the application from the small intestine, where CE has established the position as the gold standard modality for screening, to other parts of gastrointestinal tract. As CE is a less invasive endoscopic modality than conventional wired (cable) endoscopy many endoscopists were looking forward to an endoscopic evolution when CE was introduced into clinical practice. However, to our disappointment, CE has several cumbersome drawbacks, which need to be overcome before useful applications can be added. Firstly the capsule's movement is dependent upon peristalsis and gravity, secondly the short battery life, thirdly there is no method for cleansing on demand, and fourthly there is no therapeutic methodology. These drawbacks have fixed the paradigm that CE is available only for diagnosis in the long narrow tubes of the gastrointestinal tract.

To shift this stubborn paradigm, some researchers have endeavoured to overcome the drawbacks with recent advances in technology. Two major approaches to control the capsule endoscope have been proposed to date. The first is

extracorporeal magnetic control [1]–[7] and the second is wireless (radio) control [8]–[10]. The former utilizes the interactive forces between a small magnet in or over the capsule endoscope and the magnetic field generated extracorporeally. The latter is propelled by a motor or actuator and fed electric power from the batteries. Over the past few years, we have presented our versions of the two systems at medical and engineering conferences [11]–[15].

In relation to the battery life, newer more powerful batteries with a longer battery life are continually being developed and at the same time the amount of power that is consumed by electric circuits and ultra-tiny motors is decreasing rapidly owing to meeting the specifications for portable devices and robotic engineering. Improvements in power consumption and battery life will continue to extend the capsule's running time. However, having enough energy in the batteries to power other functions as well as imaging will be a big challenge. External sources of power for CE could be the answer. For example, there has been preliminary research into wireless magnetic induction [16]. However for the time being, the necessary electrical energy which is fundamentally used in the capsule can only be adequately supplied from batteries.

The clinical approach to the preparation of the colon has been focused on recently because many articles in medical journals validated that the cleanliness of the observation area are closely related to the detection rate of colorectal lesions [17], [18]. The American Gastroenterological Association (AGA) runs a big colorectal cancer awareness campaign every March, which is aimed at elderly people who have a higher risk of colon cancer. Two reasons for people not getting a colonoscopy are, (1) the procedure is painful and (2) they have to drink a large volume of unpleasant tasting preparation. CE is a less painful and more acceptable modality for screening than colonoscopy, but the dose of the preparation (6 liters) for colon capsule endoscopy (CCE) is too much for a typical Asian person to drink. Jenna et al. proposed an interesting preparation using mechanical cleansing by gas generated from a chemical reaction [19]. Several pharmaceutical companies have provided some new preparation agents such as Suprep®, Prepopick® which according to their literature are supposed to reduce the preparation dose for conventional colonoscopy. Pharmaceutical companies and many doctors (including me) are investigating acceptable preparations for CCE and a number of possible protocols have already been presented at medical conferences. As this area is getting a lot of attention, we estimated

Manuscript received December 15, 2014.

Manuscript revised January 13, 2015.

[†]The author is with Sapporo Orthopaedics and Cardiovascular Hospital, Sapporo-shi, 004-0861 Japan.

a) E-mail: hideohta@true.ocn.ne.jp

DOI: 10.1587/transcom.E98.B.526

that this drawback should be solved in a few years. Introducing treatment by CE into medicine is one of the dreams of gastroenterologists, but it is still a long and tough way to our destination, even though innovation has realized various dreams. Only a few researchers have reported on their prototypes for therapeutic CE to date [20], [21]. Furthermore, to the best of our knowledge, there has been no other report of CE utilizing network technology which is being used to develop portable and wearable devices and is becoming common in the healthcare system. Gradually, step by step, technical innovations are about to lead to a paradigm shift in CE. In this report, I present our newest magnetic navigation system for CE which at the time of writing this paper was undergoing a clinical trial, and our preliminary study on therapeutic robotic endoscopes controlled via the Internet remotely, which we hope will be patient friendly. In addition, I will evaluate the advantages of this original idea of introducing network technology into endoscopy by comparing it with recent developments in CE.

2. Materials and Methods

2.1 Magnetic Navigation (MNCE)

2.1.1 System Architecture

Our magnetic CE navigation system was composed of 4 sub-systems; 1) a capsule (diameter 11.6 mm, length 31 mm) equipped with two cameras and a magnetic disk (diameter 6 mm, depth 0.5 mm, 0.2T (Tesla), weight 0.1 g) and also had a “weightless condition” in water as reported previously [15]. A magnetic paddle, consisting of four 0.5T magnetic rods, could concentrate the force in an optimal direction (Fig. 1A). 2) a real-time viewer with remote desktop software and position display (Fig. 1B, C), 3) an ileocecal valve checker (ICVC) with beeper (Fig. 1D) and 4) a data analysis system consisting of a data recorder and a workstation.

2.1.2 Using a Web Camera System to Check Images on the Real-Time Viewer and the Location of the Capsule

To simplify the system, the image signal and position data were sent from the laptop connected to the web camera at the patient’s side to the hospital via the Internet and controlled by web camera software installed on a windows PC functioning as a real-time monitor in a hospital.

There are several methods which can be used to detect the position of the capsule (Fig. 2). The traditional way is to calculate the intensity of the wireless wave signal at 8 electrodes on the body surface (Fig. 2(a)) [22]. The capsule’s position can also be worked out from the static magnetic intensity detected at magnetic impedance (MI) sensors by cancelling terrestrial magnetic interference (Fig. 2(b)), which is similar to the method used for the ileocecal valve checker that is explained in more detail below, and has been discussed in EMBC 2014 proceedings [15]. Its position can

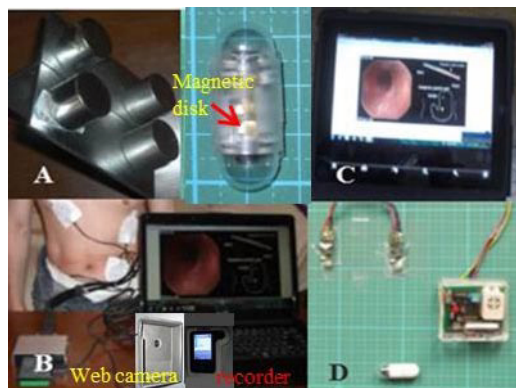

Fig. 1 Our newly designed subsystem for magnetic navigation.

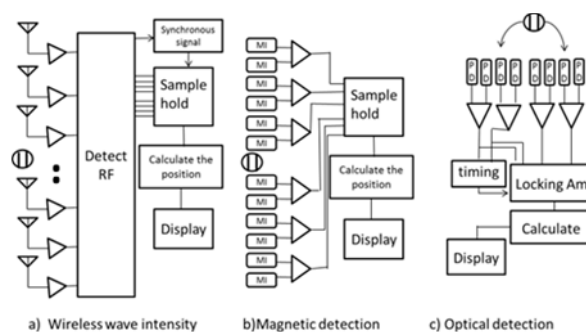

Fig. 2 Three systems for detecting the location.

also be located by detecting the minute optical power intensity from the capsule’s LEDs synchronously, under an optical shield which eliminated the external light (Fig. 2(c)).

As recognition of the capsule position in real time was necessary for quick, optimal and skillful maneuvering of the paddle, the magnetic approach could not be used in this case because the manipulation of the extracorporeal magnet paddle hindered the detection of weak magnetic field generated by the magnetic disk inside the capsule. We used a simple classical method to calculate the position from the intensity of the wireless signal here, which gave us an approximate position. We are now investigating the possibility of using a synchronous optical detection approach to establish the capsule’s precise location and recognize the camera direction too.

To minimize the time the doctor spent manipulating the paddle, the capsule was only manipulated during gastric and colonic exploration. The doctor called the subject back to the hospital after confirming that the capsule had arrived at the ileocecal valve (ICV) by checking images from the real-time monitor via the Internet.

A pair of sensors was used in order that the ICVC could distinguish between the local terrestrial magnetism (0.04 mT) and magnetic flux of similar intensity generated by the magnetic disk in the GI tract, was far from the body surface, and as a result prevented the ICVC from malfunctioning. The ICVC utilized the space diversity effect by comparing the difference between the voltages at both sen-

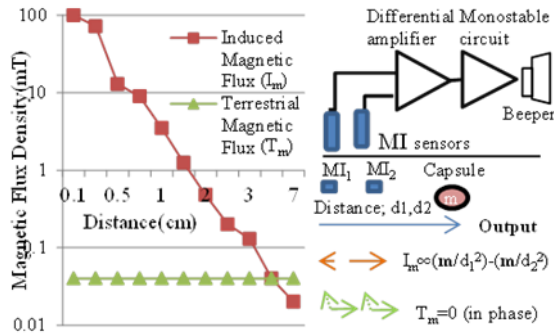

Fig. 3 Highly sensitive dual MI sensor.

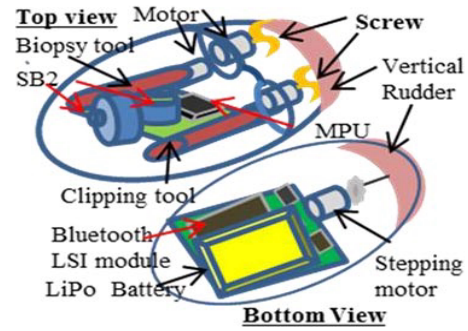

Fig. 4 Structure of the iRoboCap.

sors (Fig. 3). Fading caused by subjects moving was removed by this effect. The threshold level for detecting the capsule was adjusted to 8 or 9 cm by taking into account the anatomical ICV's location.

2.1.3 Procedure for the Entire GI Exploration

After the initial preparation, co-medical staff set up the equipment and the subject ingested the capsule followed by exploration of the stomach and proximal duodenum under magnetic navigation which was supported by observing the real-time monitor remotely. After the booster preparation, the ICVC was attached to the patient on the body surface closest to the ileocecal area and switched on. The real-time viewer was detached from the subject and carried by the subject. From then onwards, the subject became free and could go anywhere, home, office and so on. When the capsule arrived at the cecum, it set off the ICVC's beeper. On hearing the beeper, the subject phoned the hospital, attached the web camera to the data recorder and connected it to the internet. After the doctor at the hospital had confirmed via the Internet that the capsule had passed through the ICV, the subject returned to hospital and the doctor then resumed navigation of the capsule in the colon and rectum. After confirming the capsule's arrival at the anus, the data recorder was detached and then the image data was analyzed on the workstation.

2.1.4 Video Streaming Software

There are several useful commercial software tools that can deliver video clips to customers via the Internet. Skype is a famous, common and easy handling tool for this purpose. In our magnetic navigation system, we did not need a remote desktop function. To our disappointment, the new data recorder for the PillCam COLON 2 does not have an output socket for a real-time viewer which the previous model had, though it does have a tiny real-time monitor. A simple cheap solution that enabled us to utilize Given Imaging's capsule endoscope system and stream endoscopic images via the Internet was to attach a camera adaptor to the data recorder and install the Skype app or a web camera app on the laptop PC.

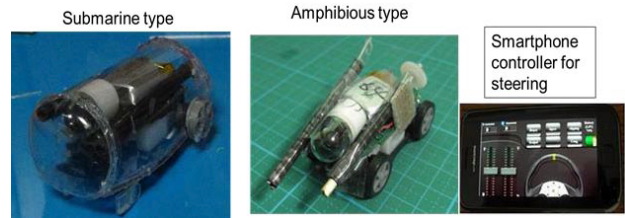

Fig. 5 The two prototypes of iRoboCap.

2.2 Motor-Driven Robotic Therapeutic Endoscopes

2.2.1 Structures of the iRoboCap

Our internet-linked and robotic capsule endoscope (iRoboCap) was used for this study. IRoboCap consisted of three parts: an imaging unit, a movement control unit and a therapeutic tool unit (Fig. 4). The imaging unit came from a Pill-Cam SB2 (Given Imaging, Yoquium Israel). Two ways of moving the iRobocap were investigated in the initial stage. One was a submarine type (screw-driven; iRoboCap-S) and the other was an amphibious type (wheel-driven; iRoboCap-A) (Fig. 5). The iRoboCap-S was equipped with three motors for movement and a driver integrated circuit, so that it could be steered three-dimensionally in water and remotely. On the other hand, iRoboCap-A was equipped with two motors and a driver integrated circuit which meant it could only move two-dimensionally. IRoboCap's therapeutic tool unit essentially consisted of a tool and a motor. The following tools (Fig. 6) were tested: a) a clipping device, b) biopsy forceps, c) a syringe for injecting or spraying, d) a rubber ligater, e) two types of scalpel and f) a balloon for dilating the stricture. The motor was used to release a mini-hemoclip, operate the forceps or trigger the spring for injection or an electromagnetic valve for generating CO₂ for balloon dilation. The tools were promptly controlled by signals generated from a single microprocessor chip on the same circuit according to sequences which were previously programmed. The mobility of each prototype and success rates of only iRoboCap-A with the several tools were evaluated in a phantom. Even though, we carefully positioned each tool on the iRoboCap-S, we were not able to maintain its

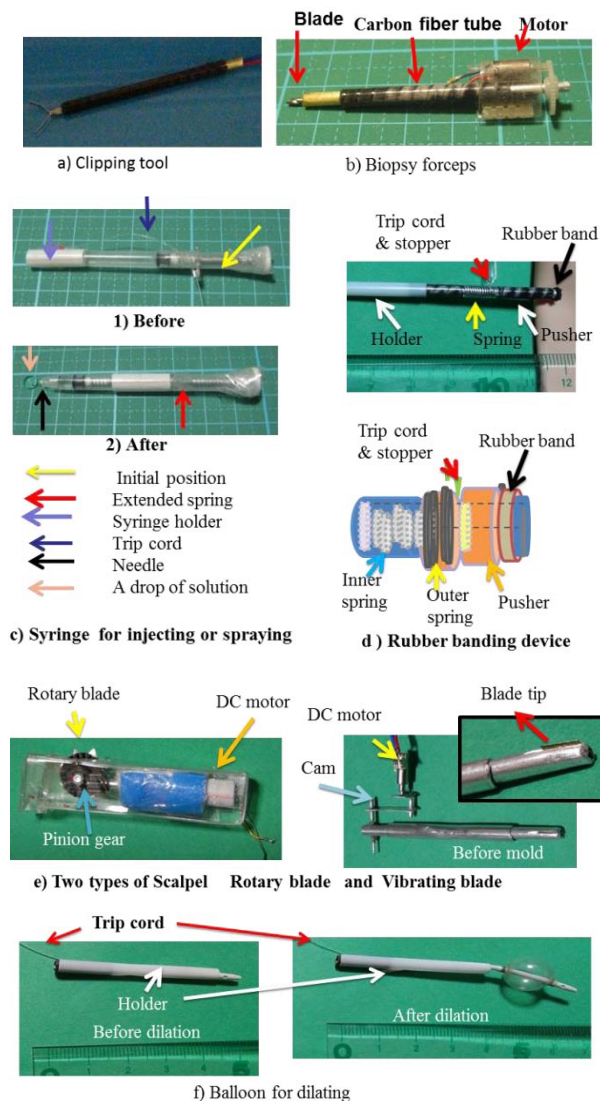

Fig. 6 Six types of therapeutic tool units.

“weightless condition” or the weight balance in water.

2.2.2 Architecture of the iRoboCap System

Figure 7 shows the architecture of the iRoboCap system. Both the S and A versions of iRoboCap used two different frequency bands and transceiver LSIs. 430 MHz was used for images and 2.4 GHz (Bluetooth or Wi-Fi specification) for control signal transmission. For security of the wireless signal, WEP or WPA encryption was used to pair each device. On the other hand, image signals from the capsule were unilaterally received by antennas on the surface of the phantom and stored on the conventional data recorder. In addition, they were sometimes simultaneously transmitted wirelessly back to the hospital via a real-time viewer linked to the Internet. A tablet device in our hospital was used to control the prototypes remotely by using application software installed on a smartphone (Galaxy; Samsung Co. or

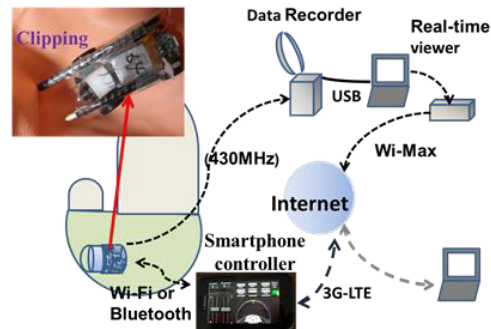

Fig. 7 System architecture of the iRoboCap.

iPhone, Apple Co.) which was next to the phantom. The smartphone was used as a repeater for the control signals between the tablet and each prototype. When each prototype was controlled wirelessly via the Internet, it was done in a different room in our hospital which was beyond the range of communication by Bluetooth or Wi-Fi. Each prototype’s microprocessor was equipped with a Bluetooth or Wi-Fi transceiver which allowed signals to be securely transferred between each prototype and the smartphone. TeamViewer (Germany), a remote desktop application was used to confirm basic transmission, control the capsule with the smartphone and to view images between the smartphone near the iRoboCap and the remote portable device. We are currently building our own bespoke app using the Xcode5 platform and it is nearly ready for testing on an iPhone 5S.

3. Results

3.1 Magnetic Navigation

3.1.1 Visual Improvements (Two Cameras and an Adaptive Frame Rate)

In CCE (PillCam COLON 2; Given Imaging) there are two major improvements which have helped to reduce the number of lesions it misses compared to conventional CE (PillCam SB2). The first is the capsule has two cameras, one at each end of the capsule, and the other improvement is the adaptive frame rate, which adjusts the timing of the flashing of the LEDs and imaging, in relation to the velocity of the capsule’s movement which is measured by the acceleration sensor. The two cameras give a wider angle of view, almost 360 degrees of visual coverage. The adaptive frame rate is linked to its low rate for missing lesions when moving fast and to the capsule’s low power consumption. Another of the capsule’s low-power features is that it does not capture the same image twice. The fixed frame rate of two frames per second (fps) of the PillCam SB2 could not prevent it from missing the lesions when the capsule was navigated quickly. Sixteen fps is the minimal rate for the video not to be jerky. Even though the frame rate of 6 fps (the maximum available for CCE) made the video a bit jerky, it was quick enough for the researchers to be able to control the capsule smoothly.

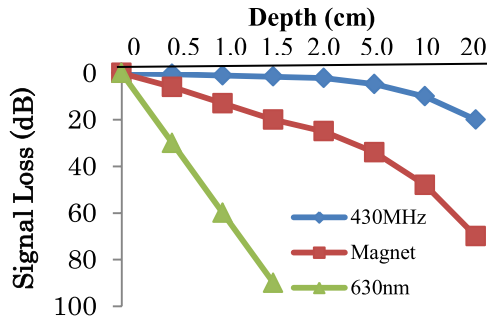

Fig. 8 The depth of penetration for each modality.

Table 1 Precision of 3 localization of capsule endoscopy.

| Modality | Wireless (430MHz) | Static magnetism | Optics (630nm) |
|------------------------------|-------------------|-------------------|----------------|
| Estimation by the wavelength | 70cm | 2mm (MI detector) | 630nm |
| Resolution in references | 2 mm | 2 mm | 1μm |

Therefore, we decided that the Pillcam COLON 2 with its two cameras and a frame rate of 6 fps was the best combination for our system.

3.1.2 Localization of the Capsule Endoscope

The location system required precision to some extent and simplicity. Under the same conditions without any additional items added to the capsule or changes in power consumption we investigated three modalities, the electromagnetic wave (430 MHz) intensity [21], the static magnetic intensity [15] and the intensity of light (630 nm) [23] for capturing endoscopic images. Figure 8 shows the signal loss in extracted porcine livers by each detection method under the sensitivity of our present detector. The conventional method by means of wireless image signal (430 MHz) intensity was the only available method. Table 1 shows a rough precision for each method, though the precision depended on the number of detector sensors and the wavelength of the modality. Using a calibration technique to revise the position, we improved the precision level. The results indicate that neither static magnetic detection nor optical detection could detect the signals well enough to calculate the capsule location to our satisfaction. Even if the optical detection system failed in our tests due to the optical scattering characteristics, we still think it could in principle be the best method for not only detecting the capsule's location accurately, but also the direction of the cameras. We hope to improve the optical permittivity in tissues by using the picosecond pulse of near infrared laser diodes. However, if that does not improve the optical permittivity, we will try to improve the signal-to-noise ratio (S/N) by using the feedforward compensation technique or the synchronous detection.

Table 2 Transit times (min.).

| | CCE | CCE+Navigation |
|---------------------------------|------|----------------|
| Gastric Transit Time (GTT) | 40.3 | 13.8 |
| Small Bowel Transit Time (SBTT) | 118 | 128 |
| Colorectal Transit Time (CRTT) | 475 | 48 |
| Completion rate (CR) (%) | 75 | 100 |

3.1.3 Transit Times and Completion Rates

Table 2 shows the average transit times, gastric transit times (GTT), small bowel transit times (SBTT), and colon-rectum transit times (CRTT) for CCE, with and without magnetic navigation. The examination time for navigation was much shorter than that for conventional CCE. With navigation the GTT was reduced by half, though the SBTT was similar to the time for CCE. Navigation resulted in completion of total GI screening within the battery life (completion rate (CR): 100%), mainly because the CRTT was only 48 minutes compared with 475 minutes for conventional CCE. To realize this high CR, postural changes were also employed during colon navigation. To our disappointment, the magnetic force was not strong enough for the capsule to overcome peristalsis or sphincter contractions.

3.1.4 Preparation and Cleanliness

For the typical Asian, 6 Liters of PEG preparation as recommended by the European Society of Gastroenterological Endoscopy [17] is too much and not acceptable. In our clinical trials, we used a total of 4.2 Liters of PEG intake, which is the same as the Japanese Capsule Endoscopic Association's protocol and was administrated in their first clinical trial for CCE [18]. However, in our trials, only 45% of the subjects drank all of the preparation due to the volume of liquid and its monotone taste. 4.2 L was especially a problem for subjects older than 65 years old, because only 10% of them managed to drink all of the preparation. Furthermore, cleanliness (in the colon and rectum), which was evaluated by a 4-point scale (excellent, good, fair, poor), scored better than fair, in only 70% of the subjects. Clinically, visibility was not good enough to satisfy most endoscopists.

3.1.5 Evaluation of the Streaming Software

In the previous model we used TeamViewer (remote desktop software) to confirm the arrival of the capsule at the ileocecal valve from the hospital. However, we found that the TeamViewer software was not suitable software for streaming video images while navigating the capsule with the magnetic paddle, because some of those images were lost and all of the images were also delayed for a few seconds. In this clinical study, we did not need a bilateral communication system between the patient and the hospital, therefore we used Skype (Microsoft) and LiveCapture3 (Daddy corp.). The former had a one second delay and the latter 0.5 seconds due to their respective coding methods, but there were no lost frames.

3.2 Remotely Controlled and Therapeutic Robotic CE

3.2.1 Communication Frequency between the Inside of the Body and the Surface of the Body

Wireless waves are absorbed by the body and the higher the frequency of the wave, the more of its energy is absorbed. There have been very few reports on the transmission of different wireless frequencies through the human body, though a few researchers [8] have used data based on the electric characteristics of tissues (fat, blood, muscle) to estimate the transmission properties of wireless frequencies in the human body. However, more than one factor needs to be considered when deciding which frequency is the most suitable for wireless communication between a transmitter inside the body and an external receiver. The decisive factor could be the one that has the greatest penetration or it could be the number of devices that use a particular frequency. In our case it was the latter. We choose the 2.4 GHz frequency band because many devices use it to communicate with other devices. In one of our previous studies (oral presentation EMBC 2014) [21], we did a simple endoscopic experiment to determine whether the 2.4 GHz frequency band was suitable or not for reliable wireless communication between a transmitter inside the GI tract and an external receiver (smartphone). The experiment demonstrated that it could be used, because even though there was about a 60 dB loss between the inside of the digestive organ and the surface of the body, the smartphone was sensitive enough to pick up the very weak signal.

3.2.2 Motion and Adjustment of Position

The dimensions of the two prototypes were nearly the same; width 22 mm, length 52 mm and height 28 mm. Both versions of the iRoboCap were equipped with a PIC24 series LSI microprocessor, which worked promptly and executed the procedure perfectly according to the program installed. iRoboCap-S was equipped with three brush DC motors (diameter 4 mm, length 10 mm), so it could be moved three-dimensionally (one motor for forward and backward, one for right and left and one for submerging and surfacing). Though they generated electrical noise, they did not interfere with the transmission of signals or the microprocessor's performance. Moreover, iRoboCap-S was equipped with two other brush DC motors (diameter 3 mm, length 8 mm) for working the therapeutic tools and again no interference was observed between the motor drive circuits and the imaging circuit. On the other hand, the amphibious type had two motors for two-dimensional movement and like the iRoboCap-S it had two smaller motors for the therapeutic devices. The fundamental movement characteristics of the two prototypes are shown in Table 3. The amphibious type could travel at a speed of 20 cm/sec maximally which was too quick for the operators to control it, in real time via the Internet. The amphibious type could not move up and

Table 3 Motion characteristics.

| | Submarine | Amphibious |
|----------------|-----------|------------|
| Forward | 8mm/sec | 20cm/sec |
| Backward | 4mm/sec | 20cm/sec |
| Right and left | 10deg/sec | 45deg/sec |
| Diving | 8mm/sec | NA |
| Surfacing | 4mm/sec | impossible |

Table 4 Characteristics of the therapeutic tools.

| Modality | Clip | Biopsy | Injection | Ligation | Scalpel | Balloon |
|----------------------|----------------|-----------------|-----------------|-----------------|----------------|-----------------|
| Size (mm) W, L, H | 3.5,40, 3.5 | 3.5, 50, 3.5 | 3.5, 55, 3.5 | 3.8, 45, 3.8 | 10, 35, 9.5 | 3.5, 45, 3.5 |
| Power(mA) | 20 | 30 | 20 | 20 | 100 | 10 |
| Success Rate (%) | 95 | 45 | 90 | 35 | 95 | 90 |
| reusable | No | No | No | No | Yes | No |

down, and as it was heavier than water, it consequently was always on the bottom of the phantom. The iRoboCap-S had a merit in that it had the ability to move three-dimensionally so it could be made to hover and keep its position. As there were several stubborn technical difficulties (weightless condition and balance in water when equipped with therapeutic devices, keeping its position, speed and pushing back from the lesion while attempting treatment) particularly with the iRoboCap-S, so the therapeutic tools were only evaluated on the iRoboCap-A in the phantom of the GI tract.

3.2.3 Success Rate for Each Treatment Tool

It was possible to control all the tools in the phantom both locally (Bluetooth) and via the Internet. However, the cuts made by the scalpel in the mucosa were a little bit rough. In retrospect, it would have been better to move the robotic endoscope slowly forwards during cutting to improve the operator's view of the lesion, so that they could have made cleaner cuts. The following problems need to be improved.

- 1) The tools occupied a large volume and therefore it was difficult to fit all the tools on one robotic endoscope.
- 2) Fixating the capsule's position and the reservoir for collecting a specimen on site to prevent the degeneration by digestive fluid were difficult due to complexity and safety in the process.
- 3) The success rates for the rubber ligation and biopsy tools were inadequate.
- 4) Only the scalpel could be reused.

3.2.4 Battery Life and Power Consumption

The LiPo battery in the iRoboCap-A prototype had a capacity of 3.7 V–150 mAh. Each motor for driving the capsule consumed 30 mA. The electronic circuit for Bluetooth and the microprocessor consumed 15 mA. Except for the scalpel, the power consumed by the therapeutic tools was negligible compared to the amount used for movement because they worked only for a short duration on demand. The amount of power in the battery meant that the iRoboCap-A had to complete the mission (explore the entire GI tract and use two tools) within 53 minutes.

3.2.5 Adaptability to the Remote Control Signal via the Internet

Controlling the present prototypes via the Internet was difficult, because we used the remote desktop software to control the prototypes via the smartphone remotely, and there was about a one second time lag between the video appearing on the real-time viewer next to the phantom and the same video appearing on the remote tablet. The delay occurred between the real-time viewer and the tablet. However, the delay was more noticeable with the iRoboCap-A, because it moved at a much faster speed than the iRoboCap-S. In addition, it was difficult to determine the orientation of the iRoboCap-A at the conventional frame rate of two frames per second. The time lag via the Internet and the fast speed at which iRoboCap-A moved, made it difficult to control via the Internet, resulting in wild steering and the missing of lesions. Neither the conventional frame rate nor the transmission speed was adequate for real-time control.

4. Discussion

Telecommunication technology and nano- technology are developing extremely rapidly. With new technological developments, it may be possible in the near future to realize the dream of diagnosis and treatment by a capsule endoscope which has multi- functions such as wireless remote control, computer assisted control and minute robotic technology.

One of our aims is to make CE as subject-friendly as possible. Our CE system introduced the Internet and robotic technology which allowed the subjects more freedom. This study has clarified the design of CE with magnetic navigation (MNCE) for screening and robotic CE with wireless control via the Internet for therapy respectively.

As our MNCE system is composed of simple inexpensive and portable parts it would be relatively easy to introduce it into daily practice at small clinics or large hospitals. The 100% completion rate indicated that magnetic navigation was an extremely useful tool for enabling the capsule to explore the entire GI tract within the life of the battery. Practically any reduction in examination time is looked upon very favorably by both doctors and patients. By using smooth muscle relaxant to reduce sphincter contractions and colonic spasms, it may be possible to reduce the examination time even more.

Evaluating the accuracy of a capsule endoscopy is important in determining if it meets the standards required for a screening modality. To the best of our knowledge, the clinical trial by Dr. Rey et al. on stomach exploration using their MNCE system is the only study to have reported accuracy findings for the upper GI tract. For the lower GI tract, Spada et al. [15] have recently reported accuracy results for the PillCam COLON, for polyps ≥ 6 mm and ≥ 10 mm. In our study, accuracy was measured in a similar way to Rey's study by comparing the results with current endoscopy (gas-

troscopy, colonoscopy).

The accuracy of GI screening is mostly related to the cleansing level, especially in the case of CE during which an endoscopist cannot wash the mucosa, aspirate mucus or erase bubbles by a bubble reducer injection. Bubbles and mucus affected the view in the upper GI tract and residual feces in the lower GI tract. The colonic cleansing level was a significant problem for colon screening by MNCE. Unlike a conventional endoscope, a capsule endoscope cannot irrigate or cleanse the colon appropriately; therefore preparations for the colorectal region need to be improved to increase accuracy, especially for colonic exploration.

A number of limitations in MNCE should be taken into account. Firstly, the force from the magnetic paddle reached only 20 cm in from the surface of the body. Sophisticated postural changes helped to improve capsule control. However, in larger individuals (all of our subjects were BMI <35) it was not as good as we expected. Control of the capsule could be improved by using stronger magnets.

A second limitation is cost. Today MR enterography and CT enterography are improving rapidly, though they still have various difficulties regarding quality to become tough competitors for CE. However, from the point of view of cost, except for the initial equipment investment, the cost of each capsule endoscopic examination is disappointingly no match for them. Capsules are disposable devices and that leads to the higher cost for this screening modality. In order to reduce costs and from an environmental standpoint, future studies should investigate the feasibility of reusing the capsule's internal hardware. A third limitation is the security of personal data on internet networks. Online fraud is a common problem. Security software that prevents leakage of personal data should be investigated.

Most gastroenterologists believe that CE is a tool only for diagnosis. It has become a kind of paradigm of CE. A few of researchers have tried to make a paradigm shift in this field. The VECTOR project is one of those studies, but to our disappointment, it has not yet developed a capsule sophisticated enough to apply it to clinical use. Furthermore, there has been no report about remotely controlling a capsule inside a patient after they had left their hospital. Control via the Internet is a common technology in the video games industry or home electronics, though it has not yet become a common technology in medicine. Some doctors might be planning to introduce remote robotic control systems into remote surgery or telemedicine because they are convenient, cost effective and the technology is more patient-friendly. A few years ago they had several difficulties due to the immaturity of robotic technology or wireless technology. However, it is now possible to remotely control a capsule over the Internet due to rapid developments in wireless technology (high speed LTE), the Internet and peripheral devices.

Wireless peripheral devices and portable devices (including smartphones or tablet devices) are developing rapidly, though they are limited to certain frequencies (800 MHz, 2.4 GHz, 5.6 GHz, etc.) Devices for internet technology contain various kinds of cheap small LSIs and

antennas which are suitable for miniaturizing equipment and establishing various functions on one circuit. Unfortunately, those frequencies mentioned earlier have large dielectric losses in the human body (so called electronic oven frequency) and therefore it was believed that transmission in the human body was impossible. But the quality of those frequency bands have been improving rapidly and their sensitivity levels have come into the target range for realizing communication between intra and extracorporeal transmitters and receivers. Valdastrì [24] and Iris De Falco [8] indicated the possibility of 0.9 GHz communication in vivo. Our previous study provided the direct evidence that the 2.4 GHz frequency band could be used in vivo. The 2.4 GHz frequency band is very useful for connecting to the Internet via wireless HUBs. Fortunately, most smartphones or tablets support 2.4 GHz Wi-Fi connectivity and/or Bluetooth connectivity. Moreover, smartphones and tablets have become very common electronic devices. If such portable devices can detect a 2.4 GHz high baud rate signal such as image signals from a capsule in the GI tract, we only need to install an application on them that is capable of storing data locally or transmitting it via the Internet, and this would mean the conventional data recorder would no longer be needed. Hopefully our quite simple system will pave the way for futuristic, impeccable and advanced remote medicine that is not only for capsule endoscopy, but also for interventional medicine including gastroenterology and surgery.

By building and trying two robotic prototypes, we have identified several areas that need to be improved in order to realize a practical version. They include the following four points, miniaturization, battery life, internet security, frame rate and high-speed transfer of video data for real-time control [25]–[27].

To miniaturize an iRoboCap to half of the size of the present prototypes, we have to look at every part. We are focusing our attention on 1) integrating the transceiver LSI with the conventional image transmitter or motor driver IC, 2) acquiring a smaller battery with a longer battery life and 3) acquiring smaller motors with low power consumption. We hope that the first problem will be overcome by introduction of a Bluetooth or ZigBee IC working at higher clock rates in the very near future. Our results indicate that the current LiPo battery would have enough power for navigation in the stomach and colon and simple therapy, however it would not have enough power for therapy that required a long operation time, such as an endoscopic mucosal resection (EMR) or an endoscopic submucosal dissection (ED). This type of battery is rapidly developing and has been introduced into various fields such as electric cars, personal computers and portable device. Unfortunately, at the moment they have safety issues and bio-batteries are still in their infancy and it will almost certainly take quite a few years before they come on to the market. If we did not need to worry about the price of the iRoboCap or think about reducing costs by reusing it, the third problem could be solved quite easily by buying expensive small low power brushless motors ($\varphi 1.5$ mm) which should help to prolong the battery

life as well as aiding miniaturization.

The most crucial problem might be internet security including secure access to cloud services. Various coding technology might be one solution as well as various new encryption techniques that are currently under development. Another approach is a fail-safe mechanism that may be also one of the better options to surmount any difficulties due to jamming of wireless communication.

The last problem concerns real-time control which was difficult via the Internet due to a delay in the video reaching the remote tablet, the slow frame rate of two frame per second and in the case of the iRoboCap-A, it was exacerbated by the high speed at which iRoboCap-A traveled. Generally speaking, the length of the time lag depended on the speed of at which images were compressed and decompressed, and the transmission rate over the internet network. Using a 4G/LTE smartphone connected to a 4G network should rectify the time lag problem, allow for faster frame rates (adaptive frame rate) and it may be fast enough to do without special software for compressing and decompressing the video images. We intend to test a 4G network connection in the very near future.

5. Conclusion

Our single capsule endoscopic system with magnetic navigation for screening the entire GI tract has the possibility to become a more subject friendly and more accurate modality for screening than conventional endoscopy, though it will be necessary to reduce costs and improve security.

Our preliminary results for robotic endoscopes show that it is possible to remotely control a robotic capsule and operate therapeutic tools via the Internet. Though our robotic system is a long way from the finished article, we are sure that rapid innovations in robotic and wireless technology will make it possible to realize many types of patient friendly systems, not only in gastroenterology but also in other healthcare areas.

Acknowledgements

I would like to especially thank Professor Makoto Kawashima of Chubu University for discussing various aspects of the circuit design and Shinichi Katsuki, a visiting professor of the Asian Institute of TeleSurgery for his helpful advice and support during our clinical trial.

References

- [1] P. Swain, A. Toor, F. Volke, J. Keller, J. Gerber, E. Rabinovitz, and R.I. Rothstein, "Remote magnetic manipulation of a wireless capsule endoscope in the esophagus and stomach of humans," *Gastrointest Endosc*, vol.71, pp.1290–1293, 2010.
- [2] J. Keller, C. Fibble, F. Volke, J. Gerber, A.C. Mosse, M.R. Zawadzki, E. Rabinovitz, P. Layer, and P. Swain, "Remote magnetic control of a wireless capsule endoscope in the esophagus is safe and feasible: Results of a randomized, clinical trial in healthy volunteers," *Gastrointest Endosc*, vol.72, pp.941–946, 2010.
- [3] J.F. Rey, H. Ogata, N. Hosoe, K. Ohtsuka, N. Ogata, K. Ikeda, H.

- Aihara, I. Pangtay, T. Hibi, S. Kudo, and H. Tajiri, "Feasibility of stomach exploration with a guided capsule endoscope," *Endoscopy*, vol.42, pp.541-545, 2010.
- [4] E. Morita, N. Ohtsuka, Y. Shindo, S. Nouda, T. Kuramoto, T. Inoue, M. Murano, E. Umegaki, and K. Higuchi, "In vivo trial a driving system for a self-propelling capsule endoscope using a magnetic field," *Gastrointest Endosc*, vol.72, no.4, pp.836-840, 2010.
- [5] J. Keller, C. Fibble, F. Volke, J. Gerber, A.C. Mosse, M.R. Zawadzki, E. Rabinovitz, P. Layer, D. Schmitt, V. Andresen, U. Rossiren, and P. Swain, "Inspection of the human stomach using remote-controlled capsule endoscopy: A feasibility study in healthy volunteers," *Gastrointest Endosc*, vol.73, pp.22-28, 2011.
- [6] J.F. Rey, H. Ogata, N. Hosoe, K. Ohtsuka, N. Ogata, K. Ikeda, H. Aihara, I. Pangtay, T. Hibi, S. Kudo, and H. Tajiri, "Blinded non randomized comparative study of gastric examination with a magnetically guided capsule endoscope and standard videoendoscope," *Gastrointest Endosc*, vol.75, pp.373-381, 2012.
- [7] U.W. Denzer, T. Rosch, B. Hotayt, N. Ogata, N. Hosoe, H. Ogata, K. Ohtsuka, X. Hebuterne, G. Vanbiervliet, J. Filippi, M. Greff, and J.F. Rey, "Prospective evaluation of magnetic gastric capsule examination (MGCE) in patients with indications for upper GI endoscopy," *Endoscopy supplement No1, 20th United European Gastroenterology Week, Amsterdam, The Netherlands*, pp.60-61, Oct. 2012.
- [8] I. Iris De Falco, G. Tortora, P. Dario, and A. Menciassi, "A integrated system for Wireless capsule Endoscopy in a liquid-distended Stomach," *IEEE Trans. Biomed. Eng.*, vol.61, pp.794-804, March 2014.
- [9] R. Carta, G. Tortora, B. Lenaerts, P. Valdastrì, A. Menciassi, P. Dario, and R. Puers, "Wireless powering for a self-propelled and steerable endoscopic capsule for stomach inspection," *Biosensors and Bioelectronics*, vol.25, pp.845-851, 2009.
- [10] M. Quirini, A. Menciassi, S. Scapellato, P. Dario, F. Rieber, C. Ho, S. Schostek, and M.O. Schurr, "Feasibility proof of a legged locomotion capsule for the GI tract," *Gastrointest Endosc*, vol.67, pp.1153-1158, 2008.
- [11] H. Ohta, Y. Sato, S. Tanaka, T. Okuda, T. Doi, A. Fujimi, and Y. Kanisawa, "A new extracorporeal magnetic navigation tool for capsule endoscopy," *Gastrointest Endosc supplement*, vol.69, *Digestive Disease Week (DDW)*, pp.98-99, Chicago, USA, May 2009.
- [12] H. Ohta, Y. Sato, S. Tanaka, F. Tamura, and T. Doi, "Capsule endoscopy for the whole of the Gastrointestinal tract using extracorporeal magnetic navigation," *Gastrointest Endosc supplement*, vol.71, pp.238-239, *DDW*, New Orleans, USA, May 2010.
- [13] H. Ohta, S. Katsuki, K. Tanaka, and T. Ebata, "A real-time dual viewer (3-D position and endoscopic image) for magnetic navigation of capsule endoscopes: Realizing simple, economical quick and accurate gastrointestinal endoscopy," *Gastrointest Endosc supplement*, vol.73, pp.370-371, *DDW*, Chicago, USA, May 2011.
- [14] H. Ohta, S. Katsuki, T. Fjita, Y. Sato, and T. Sagawa, "Total Gastrointestinal Tract Screening by using only one capsule endoscope with navigation," *Gastrointest Endosc supplement*, vol.75, pp.127-128, *DDW*, San Diego, USA, May 2012.
- [15] H. Ohta and S. Katsuki, "Subject-friendly entire gastrointestinal screening with a single capsule endoscope by magnetic navigation and the Internet," *Proc. 36th annual Int. Conf. of IEEE on EMB*, pp.6997-7000, Chicago, USA, Aug. 2014.
- [16] Y. Mao, F. Lian, and C. Yuhua, "An efficient wireless power transmission system for the capsule endoscopy application," *2011 IEEE, Biomedical circuits and System Conf.*, pp.221-224, 2011.
- [17] C. Spada, C. Hassan, M. Munoz-Navas, et al., "Second generation colon capsule endoscopy compared with colonoscopy," *Gastrointest Endosc*, vol.74, pp.581-589, 2011.
- [18] S. Oka, S. Tanaka, Y. Saito, S. Saito, Y. Kakugawa, M. Matsumoto, H. Aikawa, I. Watari, T. Aoyama, S. Nouda, T. Kuramoto, K. Watanabe, N. Ohmiya, K. Higuchi, H. Goto, T. Arakawa, and H. Tajiri, "Evaluation of the clinical efficacy of colon capsule endoscopy in the detection of lesion of the colon-prospective multicenter study in Japan," *Gastrointest Endosc supplement*, vol.79, *DDW*, pp.170-171, Chicago, USA, May 2014.
- [19] J.L. Toennie, G. Cuiti, B.F. Smith, A. Menciassi, P. Valdastrì, and R.J. Webster, "Toward Thetherless Insufflation of the GI Tract," *32nd Annual Int. Conf. IEEE on EMB*, pp.1946-1949, Boston USA, Aug. 2011
- [20] P. Valdastrì, C. Quaglia, E. Susilo, A. Menciassi, P. Dario, C.N. Ho, G. Anhoeck, and M.O. Schurr, "Wireless therapeutic endoscopic capsule: In vivo experiment," *Endoscopy*, vol.40, pp.979-982, 2008.
- [21] H. Ohta and M. Kawashima, "Technical feasibility of patient-friendly screening and treatment of digestive disease by remote control robotic capsule endoscopes via the Internet," *36th annual Int. Conf. of IEEE on EMB*, pp.7001-7004, Chicago, USA, Aug. 2014.
- [22] T. Ito, D. Anzai, and J. Wang, "Novel joint TOA/RSSI-based WCE location tracking method without prior knowledge of biological human body tissue," *36th annual Int. Conf. of IEEE on EMB*, pp.6993-6996, Chicago, USA, Aug. 2014.
- [23] T. Nakamura, Y. Nishiwaki, S. Suzuki, S. Sakaguchi, K. Oota, and Y. Yamashita, "Optical transparency of the liver tissue in various liver disease," *J. Japan Laser Medicine*, vol.8, no.3, pp.121-122, Dec. 1987. (in Japanese)
- [24] P. Valdastrì, S. Rossi, A. Menciassi, V. Lionetti, F. Bernini, F.A. Recchia, and P. Dario, "An implantable ZigBee ready telemetric platform for in vivo monitoring of physiological parameters," *Sensors and Actuators*, vol.142, pp.368-378, 2008.
- [25] H. Ohta, "The dawn of internet linked robotic capsule endoscopy: A radio-controlled and motor-driven capsule endoscope that can be controlled via the Internet," *Gastrointest Endosc supplement*, vol.77, pp.465-466, *DDW Orland USA*, May 2013.
- [26] H. Ohta, S. Katsuki, T. Fujita, Y. Sato, and T. Sagawa, "First trial of a wireless robotic capsule endoscope equipped with therapeutic tools," *Endoscopy supplement no.1 21st United European Gastroenterology Week, Berlin Germany*, pp.83-84, Oct. 2013.
- [27] H. Ohta and S. Katsuki, "A therapeutic wireless robotic endoscope controlled via the Internet remotely," *22nd United European Gastroenterology Week, Vienna Austria*, pp.789-790, Oct. 2014.



Hidetoshi Ohta received his B.S. and M.S. degrees in Electronic Engineering from Hokkaido University in 1971 and 1973, and his B.S. and Ph.D. in Medicine from Sapporo Medical University in 1988 and 1994 respectively. From 1973-82, he worked at Yokosuka Telecommunication Laboratory, NTT to study coaxial cable and optical fiber transmission systems. From 1988-2014, he has worked at several clinical hospitals, Sapporo Medical University Hospital, Hokkaido Prefectural Sapporo Kitano

Hospital, Oji General Hospital, and during that time he studied medical engineering related to gastroenterology. From 2004-11 he mentored and trained resident doctors as a clinical associate professor of Sapporo Medical University.